

Basler A100k Series



**Digital CCD Area Scan
Color or Monochrome
Camera Link® Output
Up to 15 fps at
1.45 Megapixels**

Description

The A100k Series of high-performance, digital cameras is ideal for a variety of industrial applications. The cameras can be triggered via an external sync signal or run in an internally controlled „free-run“ mode. A100k cameras operate with the easy to use Camera Link® interface. A combination of features such as low smear, test images, and indicator LEDs, ensure that these versatile cameras provide an exceptional price/performance ratio.

The A100k series cameras are ideal for applications like: Semiconductor and component inspection, manufacturing quality control, traffic control, food and beverage inspection, microscopy and medical imaging and many other vision applications. For IEEE1394 models of the A100 series please have a look at the A100f series brochure.

Basler Camera Test Tool



To ensure consistently high product quality, we employ several quality inspection procedures during manufacturing. Basler customers get a 100% tested camera, all of the benefits that go along with 100% testing, and a much higher level of satisfaction. This is a definite win-win situation.

Your benefits include:

- Superior image quality improves your image processing results
- Super compact size reduces the space needed in your installation
- 100% factory testing ensures consistent product quality
- Test image generation capability reduces your integration time and aids troubleshooting
- Area of Interest (AOI) scanning allows higher frame rates
- Low smear feature improves your performance when using a pinpoint light source
- Electronic exposure time control provides maximum flexibility

Specifications

Basler A100k Series	A102k	A102kc
Camera		
Resolution	1392 x 1040	raw: 1392 x 1040, RGB: 1391 x 1039
Sensor Type	Progressive Scan CCD	
Pixel Size (µm)	6.45 x 6.45	
Camera Link Clock	28 MHz	
Frame Rate at Full Resolution	14.8 fps	
Mono/Color	Mono	Color
Video Output Type	Camera Link (Base)	
Video Output Format	Single Pixel 8, 10 or 12 bits	Single Pixel 8, 10 or 12 bits, 24 bit RGB
Synchronization	Via external trigger or free run	
Exposure Control	Level-controlled or programmable	
Mechanical / Electrical		
Housing Size (L x W x H)	37.7 mm x 62 mm x 62 mm	
Weight	max. 292 g	
Power Requirements	12 VDC (±10%), max 3.5 W	
Mount-Type	C-mount or F-mount	
Conformity	CE, FCC	

Specifications are subject to change without prior notice

Dimensions (in mm)

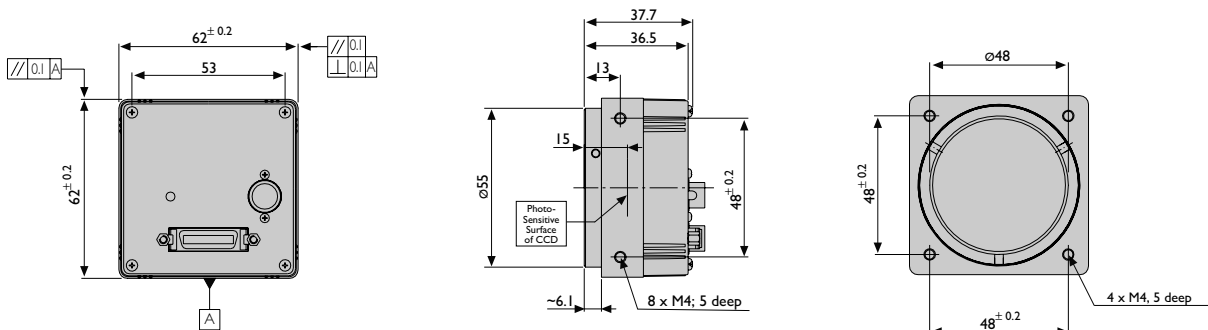

Germany, Headquarters
Fon +49 4102 463 500
Fax +49 4102 463 599
vc.sales.europe@baslerweb.com

USA
Fon +1 610 280 0171
Fax +1 610 280 7608
vc.sales.usa@baslerweb.com

Singapore
Fon +65 6425 0472
Fax +65 6425 0473
vc.sales.asia@baslerweb.com