

Basler racer

LINE SCAN CAMERAS



- Next generation CMOS sensors with 2k to 12k resolution and up to 80 kHz line rate
- Flexible and easy integration, supported by a very compact design
- Low power consumption for minimum heat and high image quality
- Outstanding price/performance ratio

OVERVIEW

Excellent Image Quality and Attractive Price/Performance Ratio

The Basler racer family uses special CMOS line scan sensors. We have added both Gigabit Ethernet and Camera Link interfaces to create a flexible, state-of-the-art technology package for the line scan market. With an outstanding price/performance ratio, this series is ideal for price-sensitive applications.

Basler racer cameras are an ideal fit for a variety of applications, including web inspection (wood, paper, foil, etc.), print inspection, surface inspection (printed circuit boards, flat panels and displays, semiconductors etc.), food inspection, document scanning, and postal sorting.

The Basler racer family features a GenICam-compliant API, and uses the latest drivers. With GUI-based software, users can easily set camera parameters, adjust image quality and control the cameras from a remote computer.

Also based on the GenICam standard, the Basler pylon driver package operates with all models of the racer series. It is available in a 32 and 64 bit version for Windows and Linux and has been proven in thousands of installations worldwide.

Your benefits include:

- Resolutions of 2k to 12k
- Line rates of up to 80 kHz
- Compact, rugged housing for easy integration
- Low power consumption for minimum heat and high image quality
- Single cable solution with Power over Camera Link (PoCL)
- Compatible with the newest vision industry standards
- Field-proven Basler pylon Camera Software Suite with both filter and performance drivers
- Outstanding price/performance ratio



TECHNICAL DETAILS

Specifications



Basler racer	raL2048-48gm	raL4096-24gm	raL6144-16gm	raL8192-12gm	raL12288-8gm
Camera					
Resolution (H x V pixels)	1 x 2048	1 x 4096	1 x 6144	1 x 8192	1 x 12288
Sensor	Awaiba DR-2k-7	Awaiba DR-4k-7	Awaiba DR-6k-7	Awaiba DR-8k-3.5	Awaiba DR-12k-3.5
Sensor Technology	Linear CMOS				
Pixel Size	7 μm x 7 μm	7 μm x 7 μm	7 μm x 7 μm	3.5 μm x 3.5 μm	3.5 μm x 3.5 μm
Line Rate	51 kHz	26 kHz	17 kHz	13 kHz	8 kHz
Mono / Color	Mono				
Video Output Format	Mono 8, Mono 12, Mono 12 Packed, YUV 4:2:2 Packed, YUV 4:2:2 (YUYV) Packed				
Interface	Gigabit Ethernet				
Pixel Bit Depth	8 or 12 bit				
Gain	Digital max. 16x				
Synchronization	Via external trigger, via software, or free-run				
Exposure Control	Trigger width or timed				
Mechanical / Electrical					
Housing Size (L x W x H)	36 mm x 56 mm x 62 mm				
Housing Temperature	Up to 50 °C				
Lens Mount	Universal front module with screwable C, F or M42 (M42x0.75, M42x1) mount adapter (available as accessory)				
Digital I/O	3 in / 2 out or direct encoder input				
Power Requirements	12-24 VDC ($\pm 5\%$)				
Power Consumption (typical)	3 W	4 W	4.5 W	5.5 W	6.5 W
Weight (typical)	ca. 300 g				
Conformity	CE, UL (in preparation), FCC, RoHS, IP30				
Software / Driver					
Driver	Basler pylon Camera Software Suite or 3rd party GigE Vision Software				
Operating System	Windows, Linux - 32 bit and 64 bit				
Conformity	GigE Vision, GenICam				

Specifications are subject to change without prior notice. Latest specifications can be found on our website. Please visit www.baslerweb.com/manuals for the detailed camera User's Manual and www.baslerweb.com/thirdparty for information on third party software.

Dimensions (in mm)

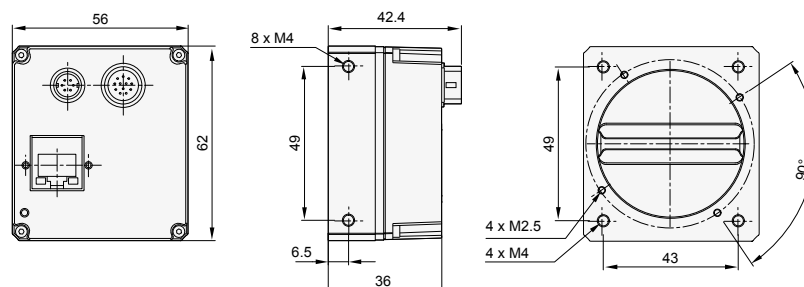

TECHNICAL DETAILS



Specifications

Basler racer	raL2048-80km	raL4096-80km	raL6144-80km	raL8192-80km	raL12288-66km
Camera					
Resolution (H x V pixels)	1 x 2048	1 x 4096	1 x 6144	1 x 8192	1 x 12288
Sensor	Awaiba DR-2k-7	Awaiba DR-4k-7	Awaiba DR-6k-7	Awaiba DR-8k-3.5	Awaiba DR-12k-3.5
Sensor Technology	Linear CMOS				
Pixel Size	7 μm x 7 μm	7 μm x 7 μm	7 μm x 7 μm	3.5 μm x 3.5 μm	3.5 μm x 3.5 μm
Line Rate	80 kHz	80 kHz	80 kHz	80 kHz	66 kHz
Mono / Color	Mono				
Video Output Format	Mono 8, Mono 10, Mono 12				
Interface	Camera Link/PoCL	Camera Link/PoCL	Camera Link	Camera Link	Camera Link
Pixel Bit Depth	8, 10 or 12 bit				
Camera Link Clock	32.5, 48, 65, 83.5 MHz				
Gain	Digital max. 16x				
Synchronization	Via external trigger via Software or free-run				
Exposure Control	Trigger width or timed				
Mechanical / Electrical					
Housing Size (L x W x H)	34 mm x 56 mm x 62 mm				
Housing Temperature	Up to 50 °C				
Lens Mount	Universal front module with screwable C, F or M42 (M42x0.75, M42x1) mount adapter (available as accessory)				
Digital I/O	Via camera control signals (max. 4)				
Power Requirements	12-24 VDC (±5%)				
Power Consumption (typical)	3 W	4 W	4.5 W	5.5 W	6.5 W
Weight (typical)	ca. 300 g				
Conformity	CE, UL (in preparation), FCC, RoHS, IP30				
Software / Driver					
Driver	Basler pylon Camera Software Suite or 3rd party GigE Vision Software				
API for Configuration	Register API or Basler pylon C++ API				
Conformity	GenICam, Camera Link				

Specifications are subject to change without prior notice. Latest specifications can be found on our website. Please visit www.baslerweb.com/manuals for the detailed camera User's Manual and www.baslerweb.com/thirdparty for information on third party software.

Dimensions (in mm)

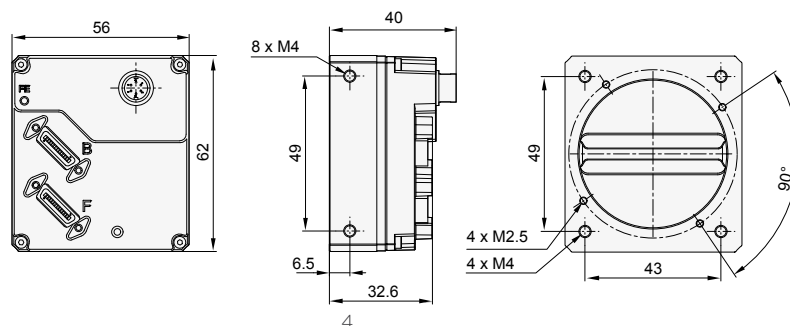

Basler pylon Camera Software Suite

The pylon Camera Software Suite operates with all Basler line scan and area scan cameras - no matter what interface they use. It offers stable, reliable and flexible data exchange between Basler cameras and PCs, at a very low CPU load.

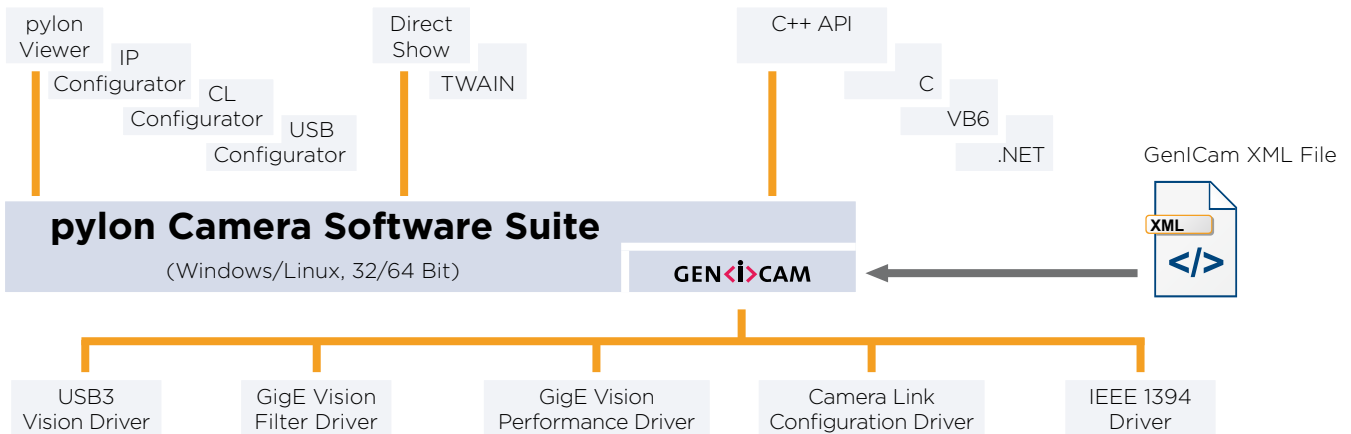

The architecture of the pylon Camera Software Suite is based on GenICam Technology, which offers you easy access to the newest camera models and the latest features. Changes to an existing camera device in your application essentially become a plug-and-play process.

An easy-to-use set of tools lets you configure the camera's interface. Use the **pylon Viewer** to set camera parameters, to capture and display images, and to evaluate the camera.

The pylon **USB3 Vision Driver** fully supports the USB3 Vision standard. It allows Basler USB 3.0 cameras to use the full speed and bandwidth of USB 3.0 for image transmission while reducing resource load and using off-the-shelf hardware components.

The pylon **GigE Vision Performance Driver** quickly separates incoming packets carrying image data from other traffic on the network and makes the data available for use by your vision application while requiring the lowest CPU resources. This driver can only be used with network cards that include specific Intel chipsets. The pylon **GigE Vision Filter Driver** supports all kinds of hardware, common GigE network cards, and GigE ports on your motherboard as well.

The pylon **IEEE 1394b Driver** gives you access to a well-established interface technology, and the pylon

Camera Link Configuration Driver offers comfortable access to all camera parameters of Basler's latest Camera Link families ace, aviator, and racer.

The pylon Camera Software Suite also contains a powerful SDK that supports any type of application development. The pylon package contains the following main modules. Each one can be individually selected/unselected during the installation process, preventing the installation of unneeded modules on your system:

- USB3 Vision Driver
- GigE Vision Filter Driver
- GigE Vision Performance Driver
- IEEE 1394 Driver
- Camera Link Serial Communication Driver
- pylon Viewer
- SDK for all cameras; C, C++, .NET (C#, VB.NET, ...), and VB6 (the 'pylon for Linux' version only supports the GigE interface via a C++ API)

The pylon Camera Software Suite can be downloaded for free at www.baslerweb.com/pylon. For more information on the installation process, refer to the pylon Installation Guide. The helpful pylon Release Notes contain all improvements and bug fixes since the first pylon version.

OTHER INFORMATION

How Does Basler Measure and Define Image Quality?



Basler is leading the effort to standardize image quality and sensitivity measurement for cameras and sensors. We are giving the EMVA 1288 standard our strongest support because it describes a unified method to measure, compute, and present the specification parameters for cameras and image sensors. Our cameras are characterized and measured in 100% compliance with the EMVA 1288 standard. Measurement reports can be downloaded from our website.

How Does Basler Ensure Superior Quality and Reliable High Performance?

Our approach to quality assurance is rigorous: we continually audit all facets of our business to guarantee performance, increase efficiency and reduce costs for our customers. We are compliant with all major quality standards including ISO9001, CE, RoHS, and more. To ensure consistently high product quality, we employ several quality inspection procedures during manufacturing.

Every Basler camera is subjected to exhaustive optical and mechanical tests before leaving the factory. We have developed a unique combination of optics, hardware, and software tools that can quickly and efficiently calibrate a camera and measure its performance against a set of standard performance criteria. Regardless of what technology or camera model you choose you can be assured of consistent performance.

3-Year Warranty

Basler offers a 3-year warranty for our cameras. We make this unprecedented promise because we have unparalleled confidence in our products. We continually reinvest in research, development and superior manufacturing capabilities so that our customers can fully rely on the products we manufacture.

About Basler

Founded in 1988, Basler is a leading global manufacturer of high quality digital cameras for industrial, medical, traffic and video surveillance applications. The company employs more than 350 people at its headquarters in Ahrensburg, Germany and subsidiaries in the United States and Asia.

Basler's portfolio of products offers customers the vision industry's widest selection of industrial and network cameras. Today it includes some 300 models – and it's still growing. We're committed to developing technology that drives business results for our customers: cameras that are easy to use, easy to integrate, and deliver an exceptional price/performance ratio.



Basler AG

Germany, Headquarters

Tel. +49 4102 463 500

Fax +49 4102 463 599

sales.europe@baslerweb.com

www.baslerweb.com

USA

Tel. +1 610 280 0171

Fax +1 610 280 7608

sales.usa@baslerweb.com

Singapore

Tel. +65 6425 0472

Fax +65 6425 0473

sales.asia@baslerweb.com

Korea

Tel. +82 707 1363 114

Fax +82 707 0162 705

sales.korea@baslerweb.com